

Product Specification

04/2017

Product LCD Display

Mode APT 750S

Abbreviation 750S

Client

Customer

audit

Supplier Tianjin APT Science and Technology Co., Ltd.

1001, Building 5 HuaDing, No.1 HuaKe 3 Road, Binhai hi-tech Industrial Development Zone, Tianjin, China

Tel TEL:+86 22 83715556
FAX:+86 22 83719955

Email yzhao@aptdevelop.com

1. Product Name

- ◇ TFT LCD display
- ◇ Model : APT 750S

2. Suppliers

- ◇ Tianjin APT Science and Technology Co., Ltd.
- ◇ Email : yzhao@aptdevelop.com apt@aptdevelop.com

3. Electrical Parameters

- ◇ 3.2inch Segment screen
- ◇ 24V/36V/48V/55V battery supply
- ◇ Rated operating current : 40mA
- ◇ Off leakage current < 1uA
- ◇ Max output current to controller : 100mA
- ◇ Operating temperature : -20~70°C, Storage temperature : -30~80°C

4. Dimensions & Material

- ◇ Product shell is ABS, transparent window is made with high strength Acrylic.
- ◇ Dimensions : host/L110mm*W68.2mm*H68mm



5. Features

- ◇ Suitable for low temperature, Max -20°C.
- ◇ 3.2inch Segment screen.

- ◇ Ergonomic external button design, easy to operate.
- ◇ **Speed display:** AVG SPEED, MAX SPEED.
- ◇ **Kilometer / Mile:** Can be set according to customers' habits.
- ◇ **Smart battery indicator:** Provide a reliable battery indicator.
- ◇ **9-level Assist :** 3-level/5-level/9-level optional.
- ◇ **Mileage indicator:** Odometer/Trip distance.
- ◇ **Power indicator:** real time power indicator.
- ◇ **Error code indicator.**
- ◇ **Software upgraded:** Software can be upgraded through UART.

6. Screen instructions

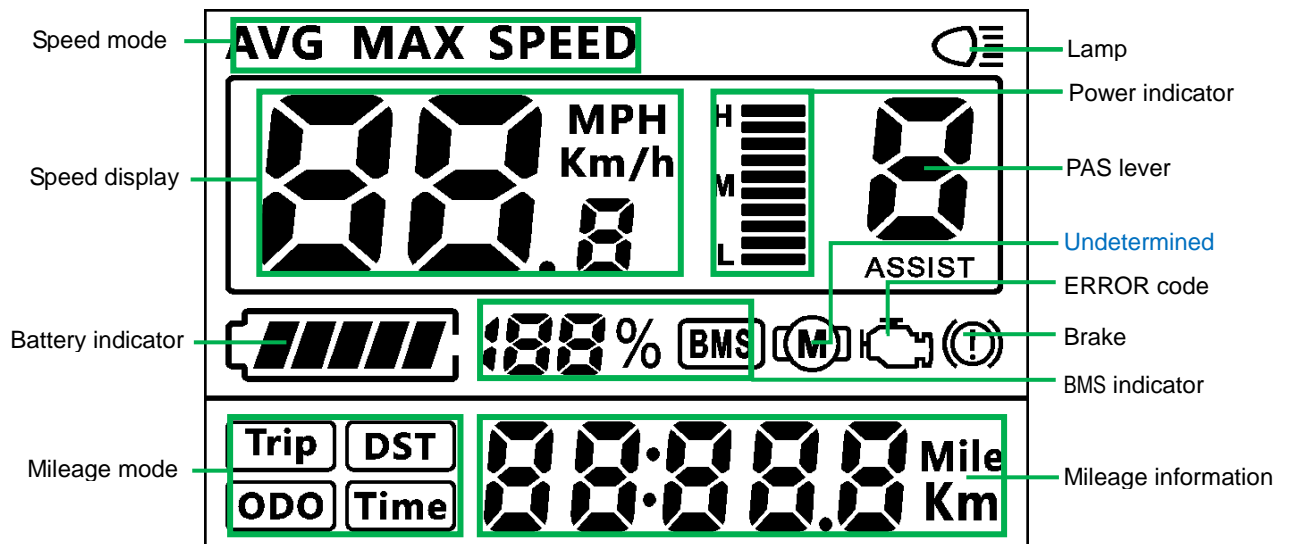

7. Functional Description

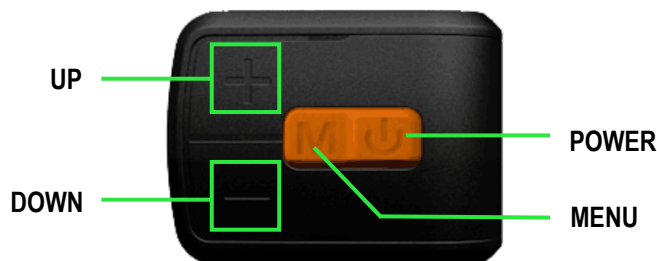

7.1 Power On/Off

Press and hold **Power** button for 1 second can turn on/off the display. The Display can automatically shut down when there is no operate & ride for X minutes (X could be

0~9) .

7.2 Assist level operating

Short press **UP/DOWN** button can change the assist level. Top assist level is 9, 0 for neutral. Level quantities can be adjusted according to the customer requirements.

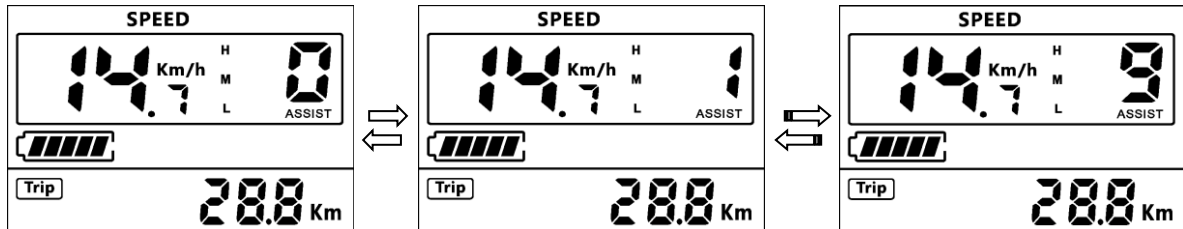

7.3 Speed mode switch& Mileage mode switch

Short press **MENU** button can change the speed mode, **Speed->AVG Speed->MAX Speed->Trip->ODO**.

*If there is no operation for 5 seconds, display will return Speed display automatically.

7.4 Headlight/backlight On/Off

Press and hold **UP** button for 1 second can turn on/off the headlight, and the screen will switch to the corresponding mode.

*The motor does not work when the battery voltage is low, Display still can keep the headlight on for a while when E-bike is in riding.

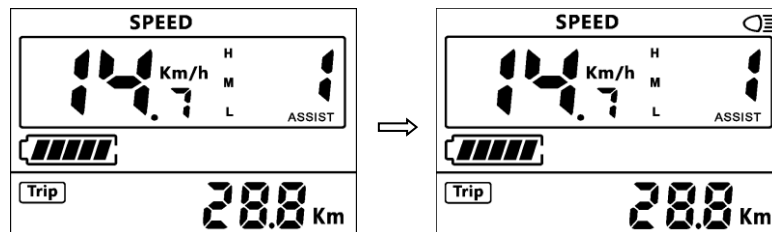

7.5 Walking mode (6km)

Press and hold **DOWN** button for 2 second can get into walking mode, out of the mode when release the button.

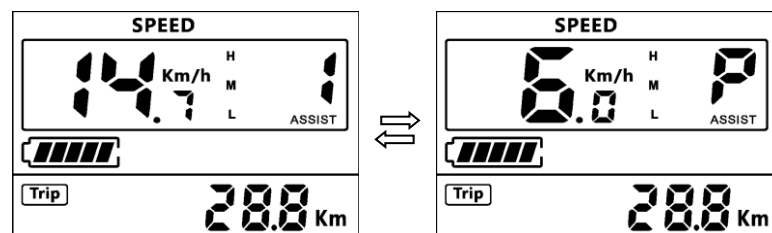

* This feature needs to be supported by controller.

7.6 Data cleanup

Press and hold **UP** & **DOWN** buttons together for 1 second can reset several temporary data, temporary data include **AVG Speed / MAX Speed / Trip**.

* These temporary data can't be erased by power off.

8. Parameter setting

Double press **MENU** button (press interval less than 0.3 second) can get into setting menus, press **UP/DOWN** buttons to change the parameter setting, press **MENU** button can switch to next item. Double press **MENU** button will exit from menu.

* Display will automatically quit menu when there is no operation for 10 seconds.

* For safety reasons, display can't get into MENU when riding.

* Display will quit MENU when start riding.

The order of parameters is as follow.

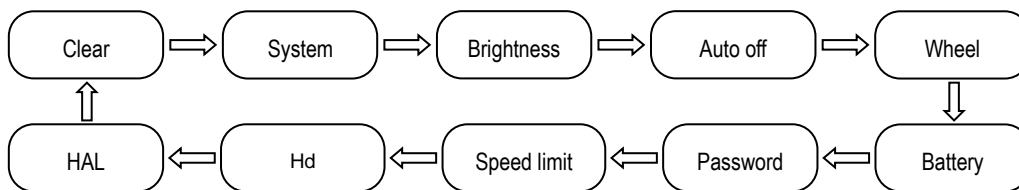

8.1 Clear (Cr): Press Up / Down button to switch between **n** / **y** (yes).

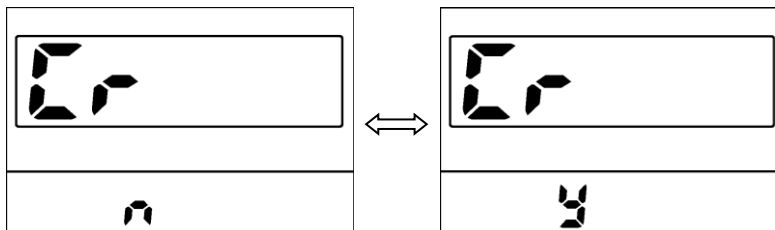

8.2 System (S7): Press Up / Down button to switch between Metric / Imperial.

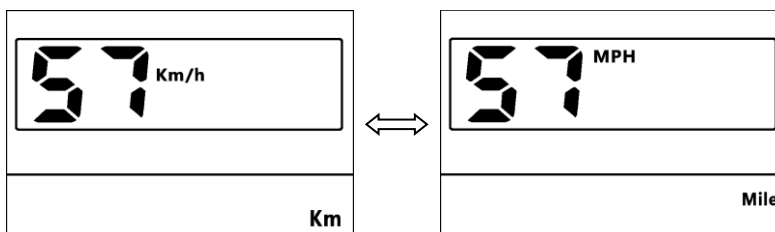

8.3 Brightness (bL1) : Press Up / Down button to change the brightness of the backlight, **1** is darkness, **5** is brightness.

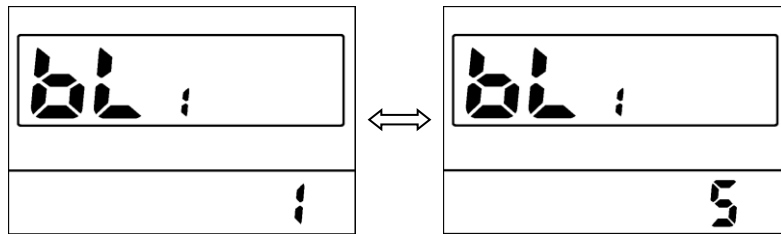

8.4 Auto off (Off) : Press UP/DOWN button to change the auto power off time, from 0 to 15, the number represent time (minutes) to shutdown, default value is 5 minutes.

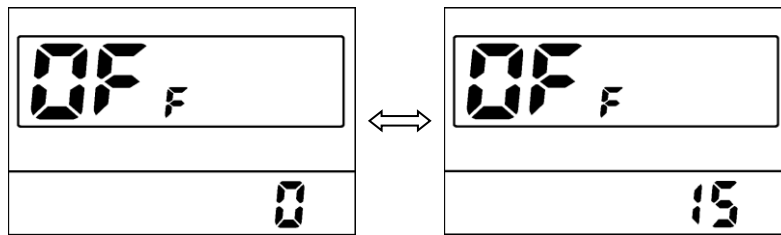

8.5 Wheel (dH): Press UP/DOWN can change the wheel setting, optional wheel diameter is 16/18/20/22/24/26/27/28/700C/29 inch.

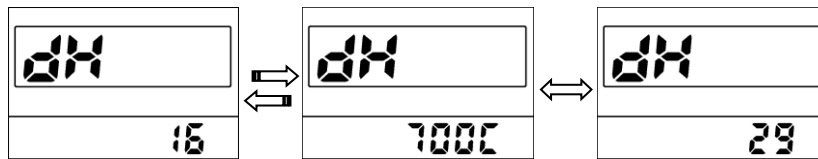

8.6 Battery (bU0): Press UP/DOWN will change battery voltage setting, optional value is 24V/36V/48V/UBE (55V), UBE means user define value.

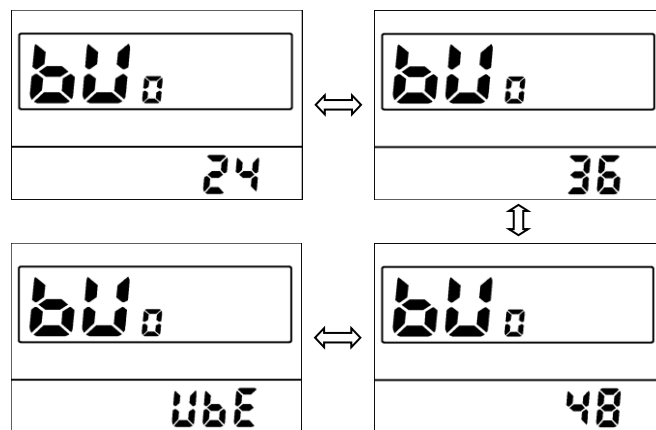

8.7 Password/Speed limit set (PSd): Press **UP/DOWN** buttons to change the password value (0~9), short press **MENU** button to switch the password item, password is 4 digits, the default password is "1919". Press **POWER** button when password adjustment is completed. Display will return to the **Voltage set** item if the password is incorrect. Correct password will enter the **Speed limit set** item.

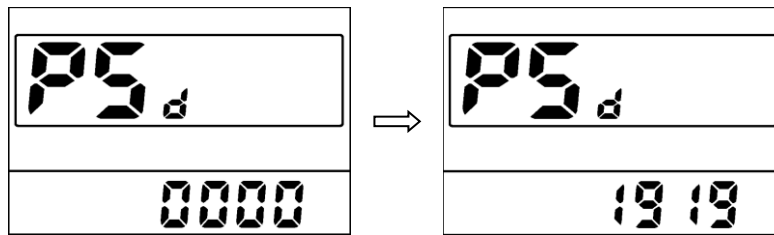

8.8 Speed limit (SPL): Press UP/DOWN will change speed limit, range 10km/h~41km/h. Default value is 25km/h.

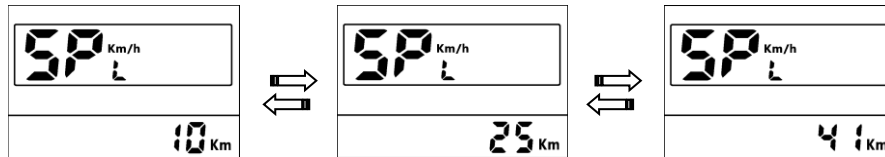

8.9 Throttle setting (Hd): Press UP/DOWN can change the parameter from 0 - 1, it change the throttle's action, 1 mean walking mode (6km/h), 0 means max speed.

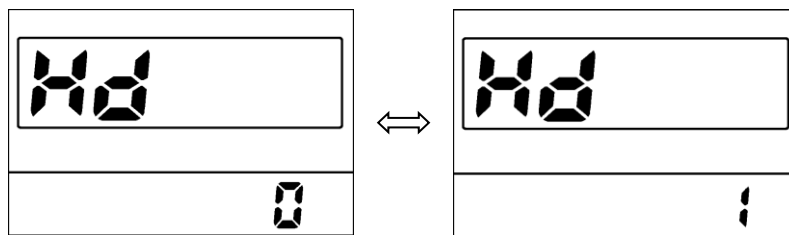

8.10 Magnetic pole numbers of speed sensor (HAL): Press UP/DOWN can change the parameter from 1 to 15(common value is 1 or 6).

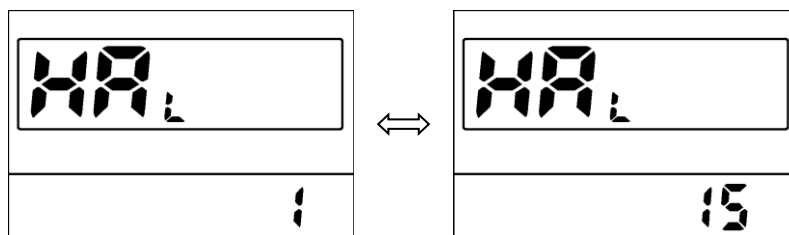

9. Error Code define

750S can show warning message,  icon shows on the screen, and show error code at the bottom of the screen, error code from 21~25, definition see the table below.

Error Code	Error description	Handle
0x21	Current abnormality	Check the controller
0x22	Throttle error	Check turn to connect.
0x23	three-phase power error	Check three-phase power line connection
0x24	Hall sensor error	Check the hall connection
0x25	Brake error	Check the brake connection.

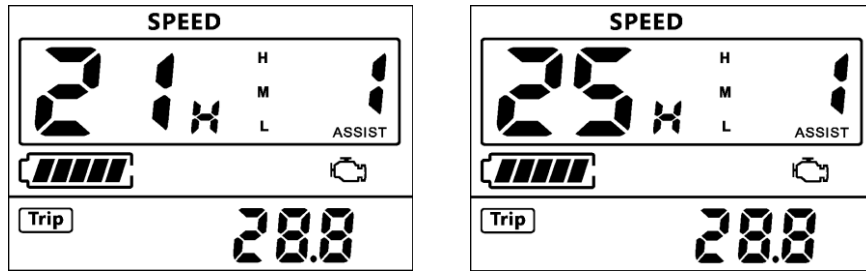

10. Assembly instructions

Please pay attention to the screw's torque value, damaged caused by excessive torque is not within the scope of the warranty.

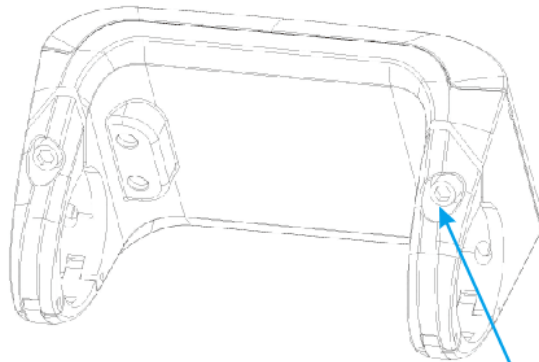

M4*10
STD=0.1N.M
MAX=0.2NM



M3*8
STD=0.25N.M
MAX=0.4N.M

Clamps suit for 3 size of handlebar, 31.8mm, 25.4mm, 22.2mm, there are transfer rings for

25.4mm and 22.2mm (marked with L or R), transfer ring must be assembled with the special directions, pay attention to the green arrow below.

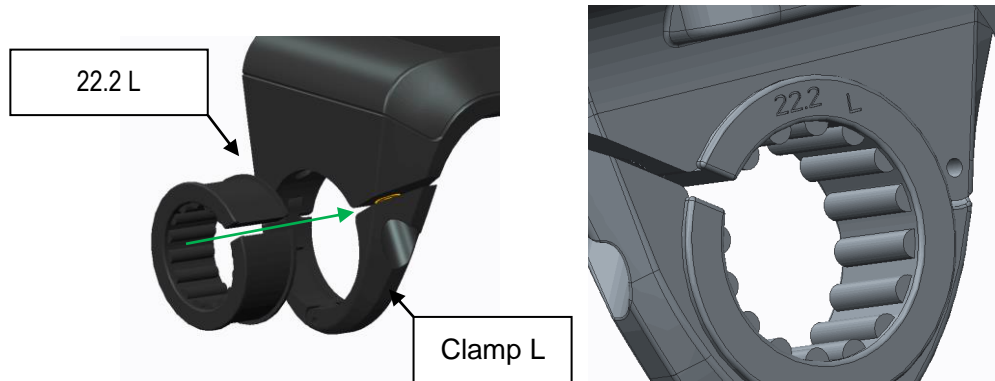

11. Connector descriptions

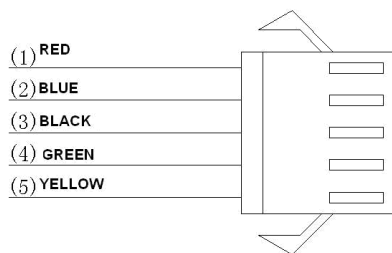

- 1、 Red wire : Anode(24v/36v/48V/55V)
- 2、 Blue wire : Power cord to the controller
- 3、 Black wire : GND
- 4、 Green wire : RxD (controller -> display)
- 5、 Yellow wire : TxD (display -> controller)

12. Assist level instructions

Assist level can be customized, the highest level is 9, common used assist level see the table below:

3 level	5 level	9 level	
0		0	No power assist
	1	1	
		2	
1	2	3	
		4	
	3	5	
2		6	
	4	7	

		8	
3	5	9	

13. Certification

CE / IP65 (water proof) / ROHS.